

## CASE STUDY

# THE USE OF BCP12 IN A PROCESS SUMMARY SMALL DIGESTER TRIAL

A city in Northern Ontario owns and operates a Water Pollution Control Plant (WPCP). This plant provides primary treatment, phosphorus removal, and anaerobic sludge digestion for the entire serviced area of the city. Disinfection of the effluent occurs on a seasonal basis, from April to October. The treatment facility has a design capacity of 109 million litres per day. The population of the city was 109,016 as recorded by Statistics Canada in March 2002 and the population served by the Water Pollution Control Plant is approximately 100,000.

The digesters retain the sludge for approximately 30 days. The temperature in the digesters is maintained at approximately 35°C and the digester contents are mixed and heated to support the breakdown of the sludge by anaerobic bacteria. Methane gas is produced during the anaerobic digestion process and is pumped back into the digesters to provide mixing. Excess methane gas is piped to the four plant boilers for fuel, supplying heat for the digestion process and plant buildings.

### SLUDGE PROCESS SCHEMATIC Thunder Bay Water Pollution Control Plant

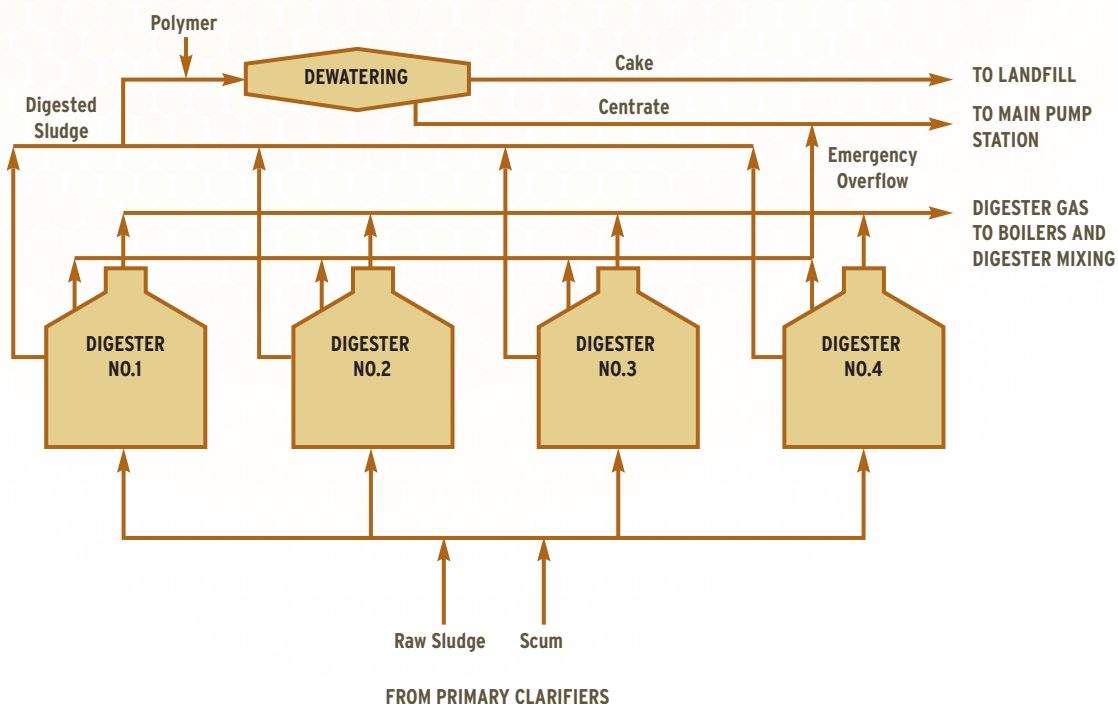

# THE USE OF BCP12 IN A PROCESS SUMMARY SMALL DIGESTER TRIAL

Digester gas production since the introduction of TWSS is presented below. Generally, gas production has been poor. Reduction of the volatile component of the sludge has been good. It is only the conversion to methane that has been poor.

During March a small trial was performed using a digester additive (bugs) to boost conversion to methane formers. The additive was added to digester 1 & 2 exclusively. During the period when bugs were added (boxed sections of the figure above) there was an increase in gas production.

The cost of the additive used in all four digesters would be \$25 per day and the reduction in natural gas use would save the plant conservatively \$200 per day. The calculation is based on using the difference between the two peaks "with bugs" and "TWSS off" with the secondary shut down. Therefore, at this point during heating season the plant should begin daily dosing of digester enhancement BCP12 by Bionetix.

## DIGESTER GAS PRODUCTION

